

## Testing and Diagnosing PC Boards

The MicroMaster ( $\mu$ Master) processor board test solutions from International Test Technologies can be used to test all types of CPU-based boards. This application brief shows how the solution can be configured to test PC motherboards (desktops, notebooks, and servers).

The tester is driven by an external PC, and consists of a CPU emulator, which takes control of the UUT's processor. Once in control, test programs and diagnostics can be directed and sequenced under the control of the host PC. Additionally an I/O emulator is available, which provides the facilities to stimulate and/or measure activity on the boards I/O connector. Using this top-down and bottom-up approach full testing can take place in seconds, rather than minutes

Figure 1 shows the components of the solution, and figure 2 shows an optional fixture, which can be used to automate the connection of UUT to the test instruments – ideal for high volume production test.

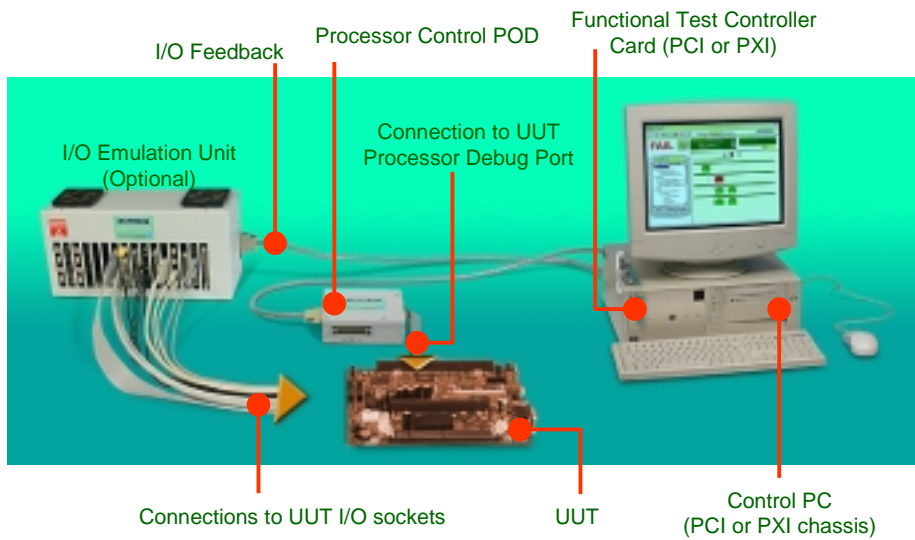

Fig. 1 – Test Solution Components



Fig. 2 – Fixture for Automated Connection

Figure 3 shows how the tester's hardware components are configured for a notebook application, and the table overleaf shows the test sequence and program, which is run by the tester. Results returned are pass/fail, or pass/fail with full diagnostics to bus and component level.

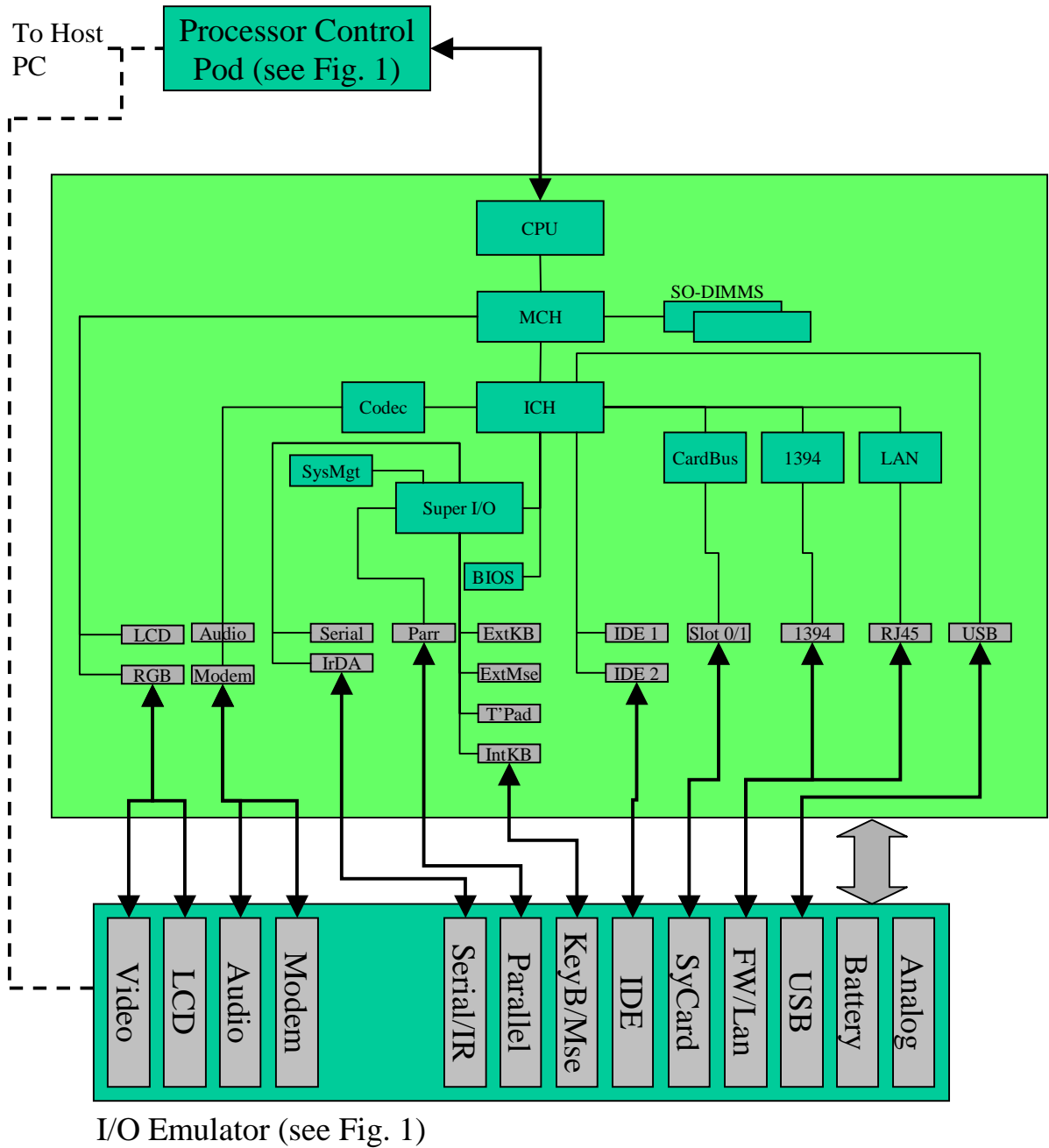

Fig. 3 – Notebook Test

## Test Sequence and Coverage

Test Name	Test Sequence	What it Tests
Power	<ol style="list-style-type: none"> <li>1. Power on UUT</li> <li>2. Check key voltages using analogue test card.</li> </ol>	<ol style="list-style-type: none"> <li>1. Soft on/off circuitry OK?</li> <li>2. Key voltages within range?</li> </ol>
CPU	<ol style="list-style-type: none"> <li>1. CPU ID Check</li> <li>2. CPU BIST Check</li> <li>3. Take control of CPU</li> </ol>	<ol style="list-style-type: none"> <li>1. JTAG OK?</li> <li>2. CPU OK?</li> <li>3. CPU infrastructure OK?</li> </ol>
General Bus	Boot ROM Bus Test	Verifies all buses from CPU to boot ROM (i.e. host, hub, PCI, LPC)
MCH	<ol style="list-style-type: none"> <li>1. Register Test</li> <li>2. Configure for normal operation</li> </ol>	<ol style="list-style-type: none"> <li>1. Verifies communications from CPU to MCH.</li> <li>2. Verifies MCH registers.</li> </ol>
SDRAM	<ol style="list-style-type: none"> <li>1. Configure memory</li> <li>2. Memory test for opens, stucks and shorts to all buses</li> </ol>	Verifies all buses and DIMM connectors from MCH to DIMMs.
ICH	<ol style="list-style-type: none"> <li>1. Register Test</li> <li>2. Configure for normal operation</li> <li>3. Legacy functions (timer, DMAC, IntC, CMOS RAM/RTC)</li> </ol>	<ol style="list-style-type: none"> <li>1. Verifies communications and buses from MCH to ICH.</li> <li>2. Verifies ICH registers.</li> <li>3. Verifies PC legacy functions.</li> </ol>
Audio/Modem	<ol style="list-style-type: none"> <li>1. Register Test</li> <li>2. Configure for normal operation</li> <li>3. Audio generation and measurement test using ITT audio card.</li> <li>4. Modem test using ITT modem card</li> </ol>	<ol style="list-style-type: none"> <li>1. Verifies ICH audio registers.</li> <li>2. Verifies communications to Codec.</li> <li>3. Verifies all audio channels for generation or measurements.</li> <li>4. Verifies modem port operation</li> </ol>
USB	<ol style="list-style-type: none"> <li>1. Register Test</li> <li>2. Configure for normal operation</li> <li>3. Data transfers to ITT's USB card.</li> </ol>	<ol style="list-style-type: none"> <li>1. Verifies ICH USB registers.</li> <li>2. Verifies USB device presence.</li> <li>3. Verifies USB channel(s) communication.</li> </ol>
IDE	<ol style="list-style-type: none"> <li>1. Register Test</li> <li>2. Configure for normal operation</li> <li>3. PIO test to ITT's IDE Emulator</li> <li>4. DMA reads and writes to ITT's IDE emulator.</li> </ol>	<ol style="list-style-type: none"> <li>1. Verifies ICH IDE registers</li> <li>2. Verifies IDE bus(es)</li> <li>3. Verifies IDE read/write DMA transfers.</li> </ol>

## Test Sequence and Coverage (continued)

Test Name	Test Sequence	What it Tests
CardBus	<ol style="list-style-type: none"> <li>1. Register Test</li> <li>2. Configure for normal operation</li> <li>3. Read/write tests to SyCard tester.</li> </ol>	<ol style="list-style-type: none"> <li>1. Verifies cardbus controller PCI bus and registers.</li> <li>2. Verifies operation of CardBus Slot 0 &amp; 1.</li> </ol>
1394	<ol style="list-style-type: none"> <li>1. Register Test</li> <li>2. Configure for normal operation</li> <li>3. Data test using ITT FW card.</li> <li>4. Optionally program GUID</li> </ol>	<ol style="list-style-type: none"> <li>1. Verifies 1394 controller PCI bus and registers.</li> <li>2. PHY operation</li> <li>3. Verifies connections from PHY to 1394 connector.</li> </ol>
LAN	<ol style="list-style-type: none"> <li>1. Register Test</li> <li>2. Configure for normal operation</li> <li>3. Transmit and receive packets at 10M and/or 100M using ITT LAN card.</li> <li>4. Optionally program MACID</li> </ol>	<ol style="list-style-type: none"> <li>1. Verifies LAN controller PCI bus and registers.</li> <li>2. PHY operation</li> <li>3. Verifies connections from PHY to LAN connector.</li> <li>4. Verifies packet transfers to/from LAN.</li> </ol>
Super I/O	<ol style="list-style-type: none"> <li>1. ID Check</li> <li>2. Register Test</li> <li>3. Configure for normal operation</li> </ol>	<ol style="list-style-type: none"> <li>1. Verifies communications from CPU to SIO.</li> <li>2. Verifies SIO registers.</li> </ol>
System Management Controller (SysMgt)?Battery	<ol style="list-style-type: none"> <li>1. EEPROM ID</li> <li>2. Smart battery interface test</li> <li>3. Battery Charge/Discharge using ITT battery simulator</li> <li>4. Temperature Sensor Check</li> </ol>	<ol style="list-style-type: none"> <li>1. Access to configuration eeprom.</li> <li>2. Operation of battery interface, and battery charge/discharge</li> <li>3. Operation of temperature sensor.</li> </ol>
Serial	<ol style="list-style-type: none"> <li>1. Register Test</li> <li>2. Loopback test of tx/rx and control lines.</li> </ol>	<ol style="list-style-type: none"> <li>1. Verifies serial controller registers.</li> <li>2. Verifies tx/rx and control lines from controller to serial port connector(s).</li> </ol>
IrDA	<ol style="list-style-type: none"> <li>1. Register test</li> <li>2. Transmit and receive bytes to/from ITT's IrDA card.</li> </ol>	<ol style="list-style-type: none"> <li>1. Verifies IrDA controller registers.</li> <li>2. Verifies transceiver.</li> <li>3. Verifies tx/rx from controller to/from IrDA card.</li> </ol>

## Test Sequence and Coverage (continued)

Test Name	Test Sequence	What it Tests
Parallel	<ol style="list-style-type: none"> <li>1. Register Test</li> <li>2. Loopback test for all data and control lines.</li> </ol>	<ol style="list-style-type: none"> <li>1. Verifies parallel controller registers.</li> <li>2. Verifies tx/rx and control lines from controller to parallel port connector(s).</li> </ol>
Ext Keyboard	<ol style="list-style-type: none"> <li>1. Register and self test to keyboard controller.</li> <li>2. Generate keypress(es) using ITT keyboard/mouse card and verify keycode at keyboard controller.</li> </ol>	<ol style="list-style-type: none"> <li>1. Verifies keyboard controller access from CPU.</li> <li>2. Verifies keyboard port.</li> </ol>
Ext Mouse	<ol style="list-style-type: none"> <li>1. Register test.</li> <li>2. Generate mouse click(s) using ITT keyboard/mouse card and verify returned codes at controller.</li> </ol>	<ol style="list-style-type: none"> <li>1. Verifies mouse controller access from CPU.</li> <li>2. Verifies mouse port.</li> </ol>
TouchPad	<ol style="list-style-type: none"> <li>1. Register test.</li> <li>2. Generate mouse click(s) using ITT keyboard/mouse card and verify returned codes at controller.</li> </ol>	<ol style="list-style-type: none"> <li>1. Verifies touchpad controller access from CPU.</li> <li>2. Verifies touchpad port.</li> </ol>
Internal Keyboard	<ol style="list-style-type: none"> <li>1. Register and self test to keyboard controller.</li> <li>2. Generate keypress(es) using ITT keyboard/mouse card and verify keycode at keyboard controller.</li> </ol>	<ol style="list-style-type: none"> <li>1. Verifies internal keyboard controller access from CPU.</li> <li>2. Verifies internal keyboard scan to internal keyboard port.</li> </ol>
BIOS ROM	<ol style="list-style-type: none"> <li>1. ID Check</li> <li>2. CRC Check</li> </ol>	<ol style="list-style-type: none"> <li>1. Verifies access to boot ROM from CPU.</li> <li>2. Verifies boot ROM contents.</li> </ol>
Video/LCD	<ol style="list-style-type: none"> <li>1. Run BIOS</li> <li>2. Initialise selected video mode(s) and verify using ITT RGB &amp; LCD check cards or operator.</li> </ol>	<ol style="list-style-type: none"> <li>1. Verifies BIOS boot.</li> <li>2. Verifies access from CPU to video controller.</li> <li>3. Verifies RGB and/or LCD ports.</li> </ol>

For more information contact:

International Test Technologies

Tel – +353-74-9188100

Email – [sales@intertesttech.com](mailto:sales@intertesttech.com)

Web – [www.intertesttech.com](http://www.intertesttech.com)